

TOOLHOLDERS

AUTOMATIC LATHES

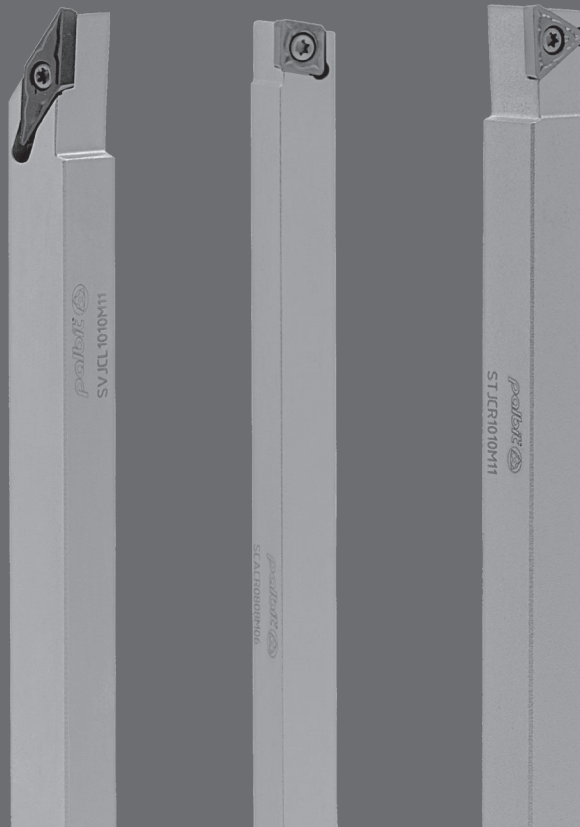

Automatic lathe toolholders efficiently hold cutting tools during automated machining. They ensure precision and consistency in high-speed operations. Quick-change mechanisms facilitate rapid tool changes, minimizing downtime and maximizing productivity in many industries.

Suportes de torno automático mantêm eficientemente ferramentas de corte durante a maquinação automatizada. Garantem precisão e consistência em operações de alta velocidade. Mecanismos de troca rápida facilitam mudanças ágeis, minimizando o tempo de inatividade e maximizando a produtividade em diversas indústrias.

Los portaherramientas de torno automático mantienen eficientemente las herramientas de corte durante el mecanizado automatizado. Aseguran precisión y consistencia en operaciones de alta velocidad. Los mecanismos de cambio rápido facilitan cambios ágiles de herramientas, minimizando el tiempo de inactividad y maximizando la productividad en muchas industrias.

Center Screw Toolholders (S) > page 836

- > Solution for ensuring easy insert exchange without interference

Solução ideal para garantir a troca fácil da pastilha sem interferência | Solución para garantizar un intercambio fácil de la plaquita sin interferencias

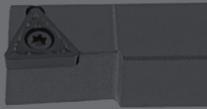



Maximize efficiency
with automatic lathes toolholders

CODE KEY FOR AUTOMATIC LATHES (ISO)

Sistema de codificação para tornos automáticos (ISO) | Codificación de herramientas de tornos automáticos (ISO)

S	C	A	C	R	12	12	M	09
1	2	3	4	5	6	7	8	9

1 - Inserts Clamping System

C	M	P	S

2 - Insert Shape

C	D	E	K
R	S	T	V
W			

4 - Inserts Clearance Angle

B	C	N	P

5 - Tool Hand

L	N	R

3 - Toolholder Leading Angle

A	B	C
D	E	F
G	H	J
K	L	M
N	Q	R
S	T	V
X	Z	

6 - Height of Shank (mm)

7 - Width of Shank (mm)

8 - Length of Holder (mm)

	D	60	P	170
	E	70	R	200
	F	80	S	250
	H	100	T	300
	K	125	U	350
	L	140	V	400
	M	150	X	Special

9 - Length of Inserts Cutting Edge (mm)

C (S) CENTER SCREW SYSTEM

TURNING

Negative inserts

Positive inserts

PCBN & PCD inserts

Heavy turning

External Toolholders

Internal Toolholders

Automatic Lathes

Spare Parts

Technical Data

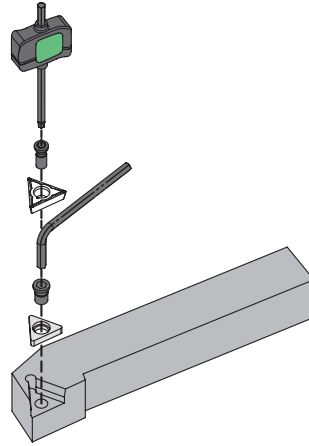

<p>SCAC 90°</p> <p>PAGE C - 837 CC.. 0602.. CC.. 09T3..</p>	<p>SCLC 95°</p> <p>PAGE C - 838 CC.. 0602.. CC.. 09T3..</p>	<p>SDAC 90°</p> <p>PAGE C - 839 DC.. 0702.. DC.. 11T3..</p>	<p>SDJC 93°</p> <p>PAGE C - 840 DC.. 0702.. DC.. 11T3..</p>	<p>SDNC 62°30'</p> <p>PAGE C - 841 DC.. 0702.. DC.. 11T3..</p>	<p>STJC 93°</p> <p>PAGE C - 842 TC.. 1102..</p>
<p>SVAC 90°</p> <p>PAGE C - 843 VC.. 1103.. VC.. 1604..</p>	<p>SVJC 93°</p> <p>PAGE C - 844 VC.. 1103.. VC.. 1604..</p>	<p>SVVC 72°30'</p> <p>PAGE C - 845 VC.. 1103..</p>			

(S) CENTER SCREW TOOLHOLDERS

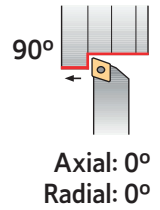
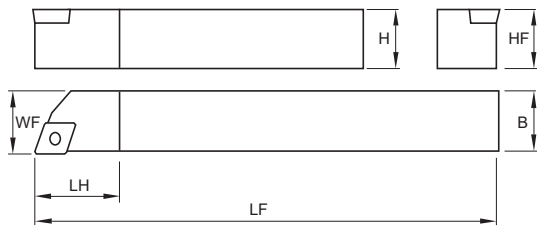

Order Code		Reference	Dimensions (mm)					Insert	WT	Stock	
R	L		HF = H	B	LF	LH	WF			R	L
212251300	212251400	SCAC R/L 0808 M06	8	8	150	8	8	CC.. 0602..	0,070		
212251500	212251600	SCAC R/L 1010 M06	10	10	150	10	10	CC.. 0602..	0,110		
212251700	212251800	SCAC R/L 1212 M06	12	12	150	12	12	CC.. 0602..	0,150		
212251900	212252000	SCAC R/L 1616 M06	16	16	150	16	16	CC.. 0602..	0,280		
212252100	212252200	SCAC R/L 1212 M09	12	12	150	12	12	CC.. 09T3..	0,150		
212252300	212252400	SCAC R/L 1616 M09	16	16	150	16	16	CC.. 09T3..	0,280		

Stock item | Produto de stock | Itens de stock

Available under request | Disponível sobre consulta | Disponible bajo consulta

SPARE PARTS Acessórios | Repuestos

Cutter Reference	Screw	Wrench
SCAC R/L 0808 M06	P0250700	XT07
SCAC R/L 1010 M06	P0250700	XT07
SCAC R/L 1212 M06	P0250700	XT07
SCAC R/L 1616 M06	P0250700	XT07
SCAC R/L 1212 M09	P0401100	XT15-S35
SCAC R/L 1616 M09	P0401100	XT15-S35

(S) CENTER SCREW TOOLHOLDERS

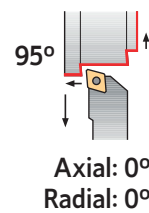
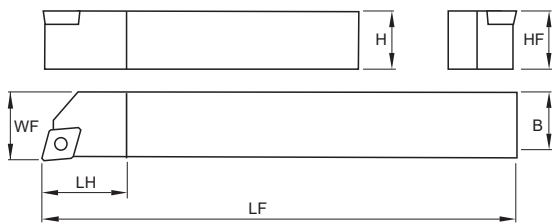

Order Code		Reference	Dimensions (mm)					Insert	WT	Stock	
R	L		HF = H	B	LF	LH	WF			R	L
212252500	212252600	SCLC R/L 0808 M06	8	8	150	8	8	CC.. 0602..	0,070		
212252700	212252800	SCLC R/L 1010 M06	10	10	150	10	10	CC.. 0602..	0,110		
212252900	212253000	SCLC R/L 1212 M06	12	12	150	12	12	CC.. 0602..	0,150		
212253100	212253200	SCLC R/L 1616 M06	16	16	150	16	16	CC.. 0602..	0,280		
212253300	212253400	SCLC R/L 1212 M09	12	12	150	12	12	CC.. 09T3..	0,150		
212253500	212250400	SCLC R/L 1616 M09	16	16	150	16	16	CC.. 09T3..	0,280		

Stock item | Produto de stock | Itens de stock

Available under request | Disponível sobre consulta | Disponible bajo consulta

SPARE PARTS Acessórios | Repuestos

Cutter Reference	Screw	Wrench
SCLC R/L 0808 M06	P0250700	XT07
SCLC R/L 1010 M06	P0250700	XT07
SCLC R/L 1212 M06	P0250700	XT07
SCLC R/L 1616 M06	P0250700	XT07
SCLC R/L 1212 M09	P0401100	XT15-S35
SCLC R/L 1616 M09	P0401100	XT15-S35

(S) CENTER SCREW TOOLHOLDERS

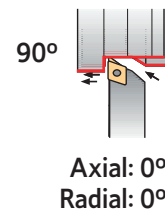
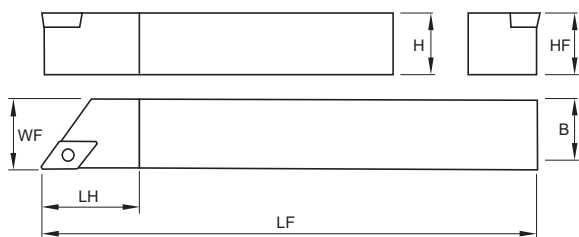

Order Code		Reference	Dimensions (mm)					Insert	WT	Stock	
R	L		HF = H	B	LF	LH	WF			R	L
212253600	212253700	SDAC R/L 0808 M07	8	8	150	12,7	8	DC.. 0702..	0,070		
212253800	212253900	SDAC R/L 1010 M07	10	10	150	15,0	10	DC.. 0702..	0,110		
212254000	212254100	SDAC R/L 1212 M07	12	12	150	15,0	12	DC.. 0702..	0,150		
212254200	212254300	SDAC R/L 1616 M07	16	16	150	16,0	16	DC.. 0702..	0,280		
212254400	212254500	SDAC R/L 1212 M11	12	12	150	18,0	12	DC.. 11T3..	0,150		
212254600	212254700	SDAC R/L 1616 M11	16	16	150	20,0	16	DC.. 11T3..	0,280		

Stock item | Produto de stock | Itens de stock

Available under request | Disponível sobre consulta | Disponible bajo consulta

SPARE PARTS Acessórios | Repuestos

Cutter Reference	Screw	Wrench
SDAC R/L 0808 M07	P0250700	XT07
SDAC R/L 1010 M07	P0250700	XT07
SDAC R/L 1212 M07	P0250700	XT07
SDAC R/L 1616 M07	P0250700	XT07
SDAC R/L 1212 M11	P0401100	XT15-S35
SDAC R/L 1616 M11	P0401100	XT15-S35

(S) CENTER SCREW TOOLHOLDERS

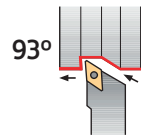
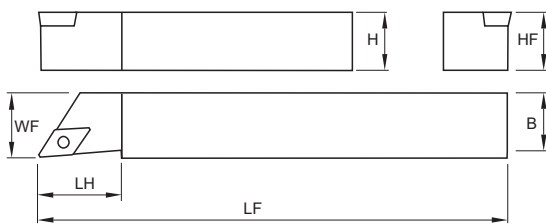

Axial: 0°
Radial: 0°

Order Code		Reference	Dimensions (mm)					Insert	WT	Stock	
R	L		HF = H	B	LF	LH	WF			R	L
212254800	212254900	SDJC R/L 0808 M07	8	8	150	8	8	DC.. 0702..	0,070		
212255000	212255100	SDJC R/L 1010 M07	10	10	150	10	10	DC.. 0702..	0,110		
212255200	212255300	SDJC R/L 1212 M07	12	12	150	12	12	DC.. 0702..	0,150		
212255400	212255500	SDJC R/L 1616 M07	16	16	150	16	16	DC.. 0702..	0,280		
212255600	212255700	SDJC R/L 1212 M11	12	12	150	12	12	DC.. 11T3..	0,150		
212255800	212255900	SDJC R/L 1616 M11	16	16	150	16	16	DC.. 11T3..	0,280		

Stock item | Produto de stock | Itens de stock

Available under request | Disponível sobre consulta | Disponible bajo consulta

SPARE PARTS Acessórios | Repuestos

Cutter Reference	Screw	Wrench
SDJC R/L 0808 M07	P0250700	XT07
SDJC R/L 1010 M07	P0250700	XT07
SDJC R/L 1212 M07	P0250700	XT07
SDJC R/L 1616 M07	P0250700	XT07
SDJC R/L 1212 M11	P0401100	XT15-S35
SDJC R/L 1616 M11	P0401100	XT15-S35

(S) CENTER SCREW TOOLHOLDERS

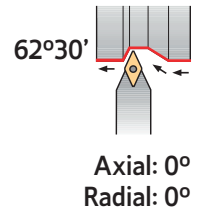
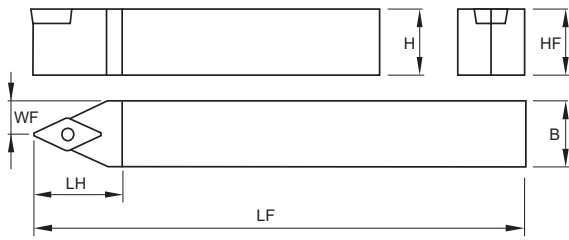



Order Code	Reference	Dimensions (mm)					Insert	WT	Stock
		HF = H	B	LF	LH	WF			
212256000	SDNC N 1010 M07	10	10	150	15	5,2	DC.. 0702..	0,100	☉
212256100	SDNC N 1212 M11	12	12	150	21	6,2	DC.. 11T3..	0,140	☉
212256200	SDNC N 1616 M11	16	16	150	21	8,6	DC.. 11T3..	0,270	☉

☉ Stock item | Produto de stock | Itens de stock

○ Available under request | Disponível sobre consulta | Disponible bajo consulta

SPARE PARTS Acessórios | Repuestos

Cutter Reference	Screw	Wrench
SDNC N 1010 M07	P0250700 	XT07 
SDNC N 1212 M11	P0401100	XT15-S35
SDNC N 1616 M11	P0401100	XT15-S35

(S) CENTER SCREW TOOLHOLDERS

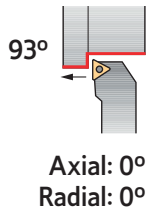
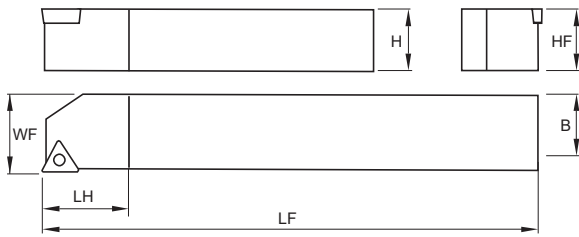

Order Code		Reference	Dimensions (mm)					Insert	WT	Stock	
R	L		HF = H	B	LF	LH	WF			R	L
212256300	212256400	STJC R/L 1010 M11	10	10	150	16	10	TC.. 1102..	0,110		
212256500	212256600	STJC R/L 1212 M11	12	12	150	16	12	TC.. 1102..	0,150		
212256700	212256800	STJC R/L 1616 M11	16	16	150	16	16	TC.. 1102..	0,280		

Stock item | Produto de stock | Itens de stock

Available under request | Disponível sobre consulta | Disponible bajo consulta

SPARE PARTS Acessórios | Repuestos

Cutter Reference	Screw	Wrench
STJC R/L 1010 M11	P0250700	XT07
STJC R/L 1212 M11	P0250700	XT07
STJC R/L 1616 M11	P0250700	XT07

(S) CENTER SCREW TOOLHOLDERS

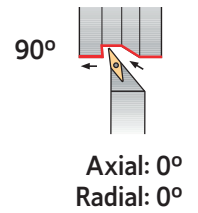
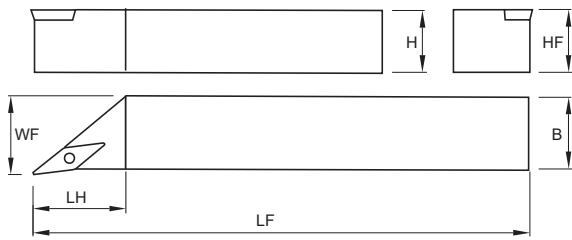

Order Code		Reference	Dimensions (mm)					Insert	WT	Stock	
R	L		HF = H	B	LF	LH	WF			R	L
212256900	212257000	SVAC R/L 0808 M11	8	8	150	26	8	VC.. 1103..	0,070		
212257100	212257200	SVAC R/L 1010 M11	10	10	150	26	10	VC.. 1103..	0,100		
212257300	212257400	SVAC R/L 1212 M11	12	12	150	26	12	VC.. 1103..	0,140		
212257500	212257600	SVAC R/L 1616 M11	16	16	150	26	16	VC.. 1103..	0,270		
212257700	212257800	SVAC R/L 1212 M16	12	12	150	40	12	VC.. 1604..	0,140		
212257900	212258000	SVAC R/L 1616 M16	16	16	150	40	16	VC.. 1604..	0,270		

Stock item | Produto de stock | Itens de stock

Available under request | Disponível sobre consulta | Disponible bajo consulta

SPARE PARTS Acessórios | Repuestos

Cutter Reference	Screw	Wrench
SVAC R/L 0808 M11	P0250700	XT07
SVAC R/L 1010 M11	P0250700	XT07
SVAC R/L 1212 M11	P0250700	XT07
SVAC R/L 1616 M11	P0250700	XT07
SVAC R/L 1212 M16	P0401100	XT15-S35
SVAC R/L 1616 M16	P0401100	XT15-S35

(S) CENTER SCREW TOOLHOLDERS

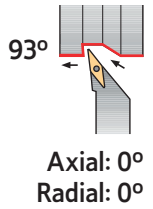
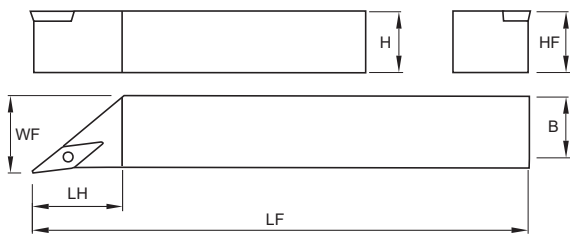

Order Code		Reference	Dimensions (mm)					Insert	WT	Stock	
R	L		HF = H	B	LF	LH	WF			R	L
212258100	212258200	SVJC R/L 0808 M11	8	8	150	26	8	VC.. 1103..	0,070		
212258300	212258400	SVJC R/L 1010 M11	10	10	150	26	10	VC.. 1103..	0,100		
212258500	212258600	SVJC R/L 1212 M11	12	12	150	26	12	VC.. 1103..	0,140		
212258700	212258800	SVJC R/L 1616 M11	16	16	150	26	16	VC.. 1103..	0,270		
212258900	212259000	SVJC R/L 1212 M16	12	12	150	40	12	VC.. 1604..	0,140		
212259100	212259200	SVJC R/L 1616 M16	16	16	150	40	16	VC.. 1604..	0,270		

Stock item | Produto de stock | Itens de stock

Available under request | Disponível sobre consulta | Disponible bajo consulta

SPARE PARTS Acessórios | Repuestos

Cutter Reference	Screw	Wrench
SVJC R/L 0808 M11	P0250700	XT07
SVJC R/L 1010 M11	P0250700	XT07
SVJC R/L 1212 M11	P0250700	XT07
SVJC R/L 1616 M11	P0250700	XT07
SVJC R/L 1212 M16	P0401100	XT15-S35
SVJC R/L 1616 M16	P0401100	XT15-S35

(S) CENTER SCREW TOOLHOLDERS

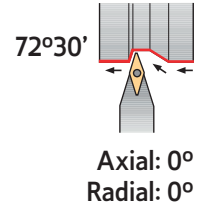
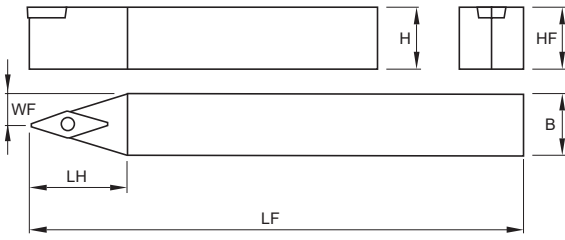

Order Code	Reference	Dimensions (mm)					Insert	WT	Stock
		HF = H	B	LF	LH	WF			
212259300	SVVC N 0808 M11	8	8	150	21	4,3	VC.. 1103..	0,070	
212259400	SVVC N 1010 M11	10	10	150	21	5,3	VC.. 1103..	0,100	
212259500	SVVC N 1212 M11	12	12	150	21	6,3	VC.. 1103..	0,140	
212259600	SVVC N 1616 M11	16	16	150	21	8,3	VC.. 1103..	0,260	

Stock item | Produto de stock | Itens de stock

Available under request | Disponível sobre consulta | Disponible bajo consulta

SPARE PARTS Acessórios | Repuestos

Cutter Reference	Screw	Wrench
SVVC N 0808 M11	P0250700	XT07
SVVC N 1010 M11	P0250700	XT07
SVVC N 1212 M11	P0250700	XT07
SVVC N 1616 M11	P0250700	XT07